



# CHANNEL VISION™

**Model 6010-B 1/3" COLOR  
Vari-FOCAL Bullet Camera**

234 Fischer Ave.  
Costa Mesa, CA 92626

**380 TV Lines, Weatherproof**  
Standard 4-9mm, Vari-FOCAL Lens  
Strong, metal structure, easy to install.

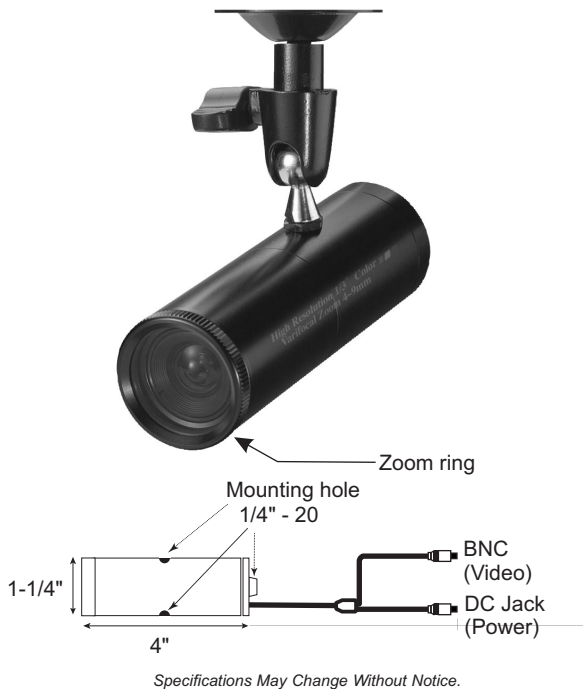

	<b>Specifications</b>
Image Sensor	1/3" Color CCD
Effective Pixels	NTSC: 512 (H) x 492 (V)
Horizontal Resolution	380 TV Lines
Synchronizing System	Internal
Scanning System	2:1 Interlaced
Video Output	1V p-p 75Ω Composite
S/N Ratio	More than 48dB (AGC off)
Minimum Illumination	0.2 Lux @ F2.0
BLC	Automatic
Shutter Speed	NTSC: 1/60 ~ 1/100,000
Gamma Correction	0.45
White Balance	2100°K~8200°K Auto
Gain Control (AGC)	Automatic
Smear Effect	0.005%
MTBF	80,000 hours
Power Source	9~12 VDC Regulated
Operating Current	90mA
Lens	4-9mm (69°) Vari-FOCAL Lens
Operating Temperature	14°F ~ 122°F (10°C ~ 50°C)
Humidity	Less than 90% RH
Output Terminal	4' Cable with BNC - Female for Video, DC Jack - Male for Power
Dimensions	1-1/4" (D) x 4" (L)
Weight	5.1 oz

500-000

## CHANNEL VISION Limited Warranty

Channel Vision Technology will repair or replace any defect in material or workmanship which occur during normal use of this product with new or rebuilt parts, free of charge in the USA, for two years from the date of original purchase. This is a no hassle warranty with no mail in warranty card needed. This warranty does not cover damages in shipment, failures caused by other products not supplied by Channel Vision Technology, or failures due to accident, misuse, abuse, or alteration of the equipment. This warranty is extended only to the original purchaser, and a purchase receipt, invoice, or other proof of original purchase date will be required before warranty repairs are provided.

Mail in service can be obtained during the warranty period by calling (800) 840-0288 toll free. A Return Authorization number must be obtained in advance and can be marked on the outside of the shipping carton.

This warranty gives you specific legal rights and you may have other rights (which vary from state to state). If a problem with this product develops during or after the warranty period, please contact Channel Vision Technology, your dealer or any factory-authorized service center.